

# Touch Access and Attendance Terminal

## **User Guide**

The leader of security access control

# Catalogue

- 1. Notice.....**
- 2. Menu.....**
  - 2.1 MENU#..... - 3 -
  - 2.1.1 Register Card.....
  - 2.1.2 User Verification.....
  - 2.1.3 User ID NO.....
  - 2.1.4 Privilege Level.....
  - 2.1.5 Initial Interface.....
- 3. REGISTER USER.....**
  - 3.1 DELETE USER.....
  - 3.2 DOWNLOAD USER INFORMATION
  - 3.3 UPLOAD USER INFORMATION.....
  - 3.4 UPLOAD USER DATA.....
- 4. SETTING.....**
  - 4.1 GENERAL SETTING.....
  - 4.2 ADVANCED SETTING.....
- 4.3 TIME SETTING.....**
  - 4.4 DEPARTMENT SETTING.....
  - 4.5 ACCESS FUNCTION.....
    - 4.5.1 UNLOCK DELAY.....
    - 4.5.2 DOOR MAGNETISM SETTING.....
    - 4.5.3 WIEGAND FORMAT.....
    - 4.5.4 OUTPUT DATA.....
    - 4.5.4 CARD NO. FORMAT.....
    - 4.5.5 LINK WITH ACCESS CONTROLLER
    - 4.5.6 CAED READER MODE.....
- 5. RECORD MANAGEMENT (U DISK DOWNLOAD)**

**6. DEVICE INFORMATION INQUIRY.....**

6.1 REGISTER INFORMATION.....

6.2 DEVICE INFORMATION.....

**7. ACCESS WIRING DIAGRAM.....**

---

**NOTE: WE ARE RESERVES THE RIGHT OF FINAL INTERPRETATION AND MODIFICATION**

---

Diagram for professional access power supply

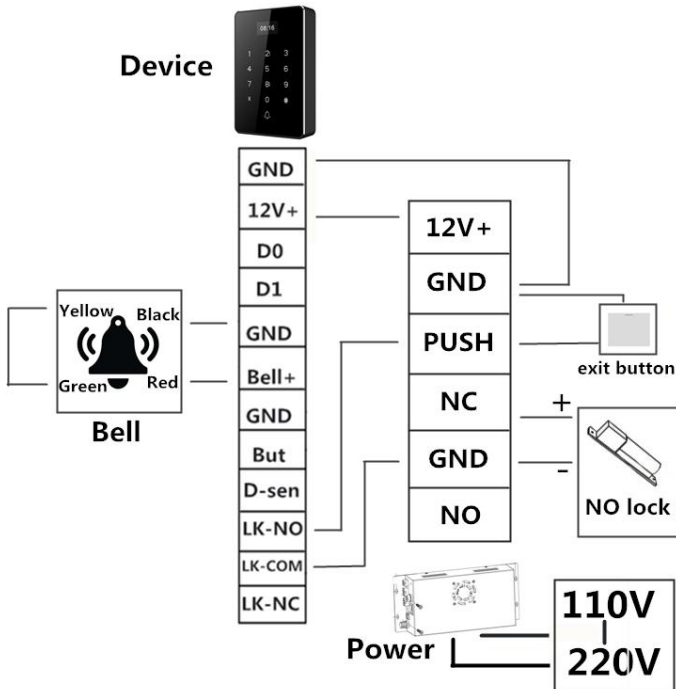

**Remark: Normal closed lock link NO and GND**

## 1. Notice

This Device is OLED LCD. DPI: 128x64

Working Temperature 0-50°C, Power supply: DC12V

- 1、 # is Menu key, \* is cancel key
- 2、 Press # key enter Menu →press 2 ↑ to move up →Press 8 ↓ to move down. After choose the right menu, then press # to confirm, and press \* to exit.

## 2. MENU

### 2.1 MENU#

Through this section use can check employee, device setting, records and so on

- Employee Management
- Manual Register New User
- Device Setting
- Security Level
- Privilege Level
- Self-help report
- Access controller card reader mode

#### 2.1.1 User card registration

Choose user register in the menu, put the card on the punch card area on the device, there will be a voice Thank you means register success

#### 2.1.2 User Verification

User registered card to punch card prompt success, unregistered card to punch card prompt invalid card

### 2.1.3 User ID NO.

When start to register, user can be assigned one ID NO. When user start to verify card, this card NO. will be used to relate this card or password.

### 2.1.4 Privilege Level

Device have 2 privilege level:

- Normal User (Do not have privilege to operate menu)
- Administrator (Set one user as administrator, the user can operate the device.)

### 2.1.5 Initial Interface

After device link DC12V and power on, the screen enters the initial standby interface, as the following Pic.



## 3. Register User

After set administrator when register normal user, need to verify admin. Card or password. As the following pic.

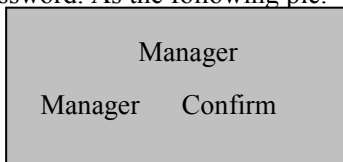

**Remark:** If no admin., press # key can enter menu.

After verify success, the screen will show the following information: press 2 ↑ and 8 ↓ key will be more information.

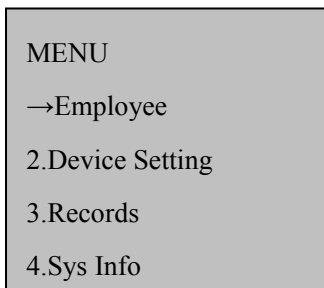

Choose **【Employee】** press #, enter menu, press 2 ↑ and 8 ↓ key will be more information, as follow

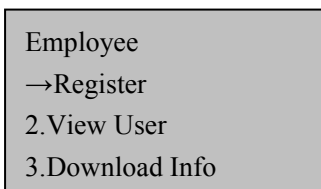

Choose **【1. Employee】** enter **【Register】** , as follow

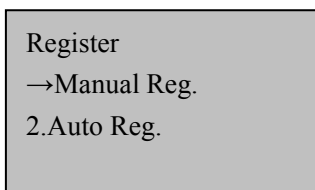

1.1 Choose **【Manual Reg.】** register new user. User also can choose registered user and modify the register information, as follow

Employee  
→ID 1  
2.NAME Wei zeng  
3.Dept Unset1  
4.Pwassword Unsr  
5.Card Unset  
6.Privileg Unset

- ID: The user ID has to be unique.
- Name: User's name
- Password: User password, input this password to verify
- Card: The card NO.
- Privilege: Set user's privilege, if set admin. then the user can enter menu to edit device information and do other operate.

1.2 Choose **【Auto Reg.】**, automatically add card when add bulk users. As follow.

In Card No.  
ID: 1/1000  
Card:

### 3.2 Delete User

Choose **【User managment→View User】**, as follow:

View User  
→User Array  
2.User Search

Choose **【User Array or User Search】** for quick search registered user

User Array →1 2 Wei zeng	User Search Input ID <u>3</u> wei zeng
1-1	1-2

Choose **【2. weizeng】** enter **【User management】** interface, as follow

Employee →ID 3 2.Name wei zeng 3.Dept Unset 4.Password Unset 5.Card set 6.Privileg User 7. delete
--

Press 2 ↑ and 8 ↓ , choose “delete” and press **#** and confirm delete.

### 3.3 Download Info

Download the register infromation from device to U-disk, then can genetate a excel file includ all the register information, the download file

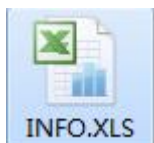

is INFO.XLS

The download user data file name is 001\_AFP.DAT (001 means machine ID) .

Choose **【User management】** , as follow



Employee  
→Register  
2.View User  
3.Download Info

Employee  
4.Upload Info  
5.Download Data  
6.Upload Data

Choose **【Download Info】** enter menu, as follow:

Working

Download OK

Choose **【3.download data】** ,after insert Udisk to device, as follow

Working

Download OK

If device can not read the Udisk, then upload and download will show as follow

Upload Fail !

Download Fail !

### 3.4 Upload user information



After download user information, open the file **INFO.XLS** in U disk as follow

	A	B	C	D
1	<b>Shifts Table</b>			
2	<b>No</b>	<b>Name</b>	<b>Department NO.</b>	
3	1	Face Miss	1	
4	2	Jason zhou	1	
5	3	wei zeng	1	
6	4	catherine luo	1	
7	5	may wang	1	
8	6	davia jiang	1	

This file is excel format, can add and modify name then save, after upload user information success device will show user name

Working

Upload Ok

### 3.5 Upload User Data

This function is move the register informaiton file 001\_AFP.DAT in the Udisk to access device.

First insert the U disk which include the register information file 001\_AFP.DAT to the device, then choose **【Upload Data】** , as follow

Working

Upload OK

## 4. Device Setting

Menu→Device Setting

Device Setting  
→General  
2.Advance  
3.Date&Time

Device Setting  
→Date&Time  
4.Manag.Dept  
5.Lock Ctrl

## 4.1 General

Choose **【General】** , enter general setting menu

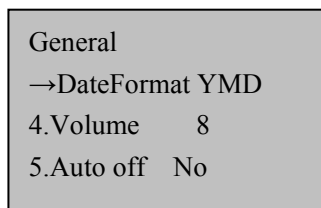
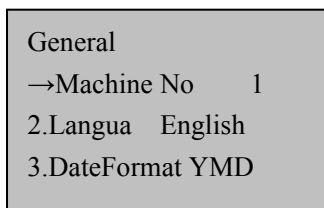

Machine NO. can set 1-255, Langua is English, Date Format can choose,Volume can be set 1-8.

Remark: Automatically power off function, we don't advice client to change the setting here.

## 4.2 Advance

Choose **【Advance】** ,enter advance setting menu, as pic. 4-1

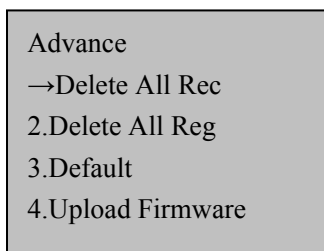

Pic 4-1

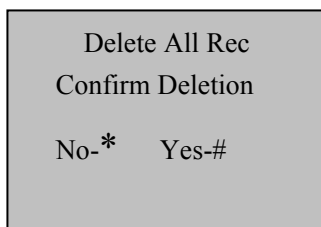

Pic 4-2

4.2. 1 Delete all records, as pic. 4-2

- **Delete all record:** Delete all the record in access device.
- **Delete all data:** Delete all the register information in access device
- **Defaults:** Reset all the parameters in device to factory values, like Machine ID reset to 1;

- **Upload Firmware:** Use U disk to upload firmware, put the firmware in u disk, make sure U disk is formatting, then insert U disk to device.

### 4.3 Date&Time

This product can be modified manually

In device menu, choose **【Date & Time】** , as the following Pic.

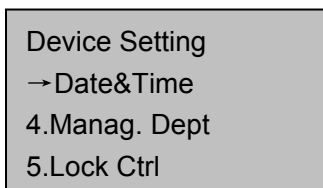

### 4.4 Manag. Dept

Set each department check in time period, choose **【Manag.Dept】** , as follow

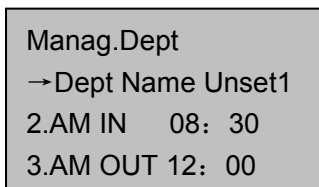
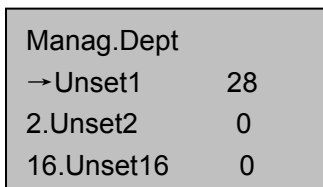

### 4.5 Lock Ctrl

In this menu to set time to open the door and other setting.

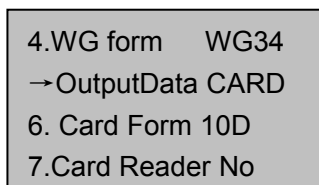
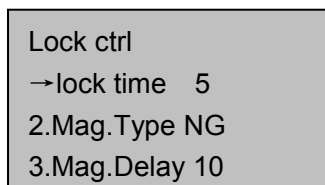

### **4.5.1 Unlock delay**

Unlock delay setting is after lock control the delay is start , it reset to normal state time space.Rang is 1-255, unit is second, default value is 5 second.

### **4.5.2 Door Magnetic Setting**

#### **A. Delay type**

Set input type of delay, in default state is NO means don't open delay fuction.

#### **B. Door Magnetic Delay**

After lock control delay back to normal state, how many hours don'ttest the door is closed then will alarm.

Open Door Magnetic Delay function is after lock control delay is start, it reset to normal state time space.Rang is 1-255, unit is second, default value is 5 second.

#### **C. Illegal open door alarm**

If don't verify identity then open the door, then it is illegal open the door, will alarm immediately.

### **4.5.3 WG Format**

Standard international WG26 or WG34 format.

### **4.5.4 Output Data**

Add 65534 before FACILITY, CARD means card NO., ID means work NO.

#### **4.5.4 Card NO. Format**

10D, 10D\_I, 8D\_N; 8D\_S

#### 4.5.5 Link with Access Controller

Link with access controller WG26 Device set CARD, WG34 and 8DN output card NO. must the same.

Link with access controller WG 34 Device set CARD, WG34 and 10D output card NO. must the same.

#### 4.5.6 Card reader mode

In this mode the device can be used as access card reader

### 5.Records (U disk to download)

User can use U disk to download report and attendance record

In **【Attn. Report】** , choose download, like pic 5-1

Choose **【Att Rec】** , and download, like pic5-2

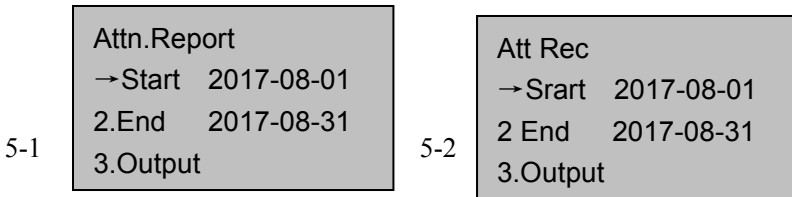

After download report success, there will be a file named

001\_2017\_08\_MON.XLS in U disk, this is the access report

After download attendance records success, there will be a file

named 001\_GLog.txt in U disk, this is the attendance record.

## 6.Sys Info

**【Sys Info】** is to search some information for the device,like the register information , device information

### 6.1Reg.Data

Show the registered information in the device, press # key and enter.

User Reg: 28/1000  
 Password: 1/1000  
 ID Card: 28/1000  
 Attend Rec: 180/100000

## 6.2 Device Info.

Show product information in the device, press # key and enter.

Maker : Z Co.,LTD  
 Device : A800  
 Date : 2017-08-08  
 Firmware: CPM1\_V1.04

# 7. Access device wiring diagram

7.1 常闭锁接线 如图

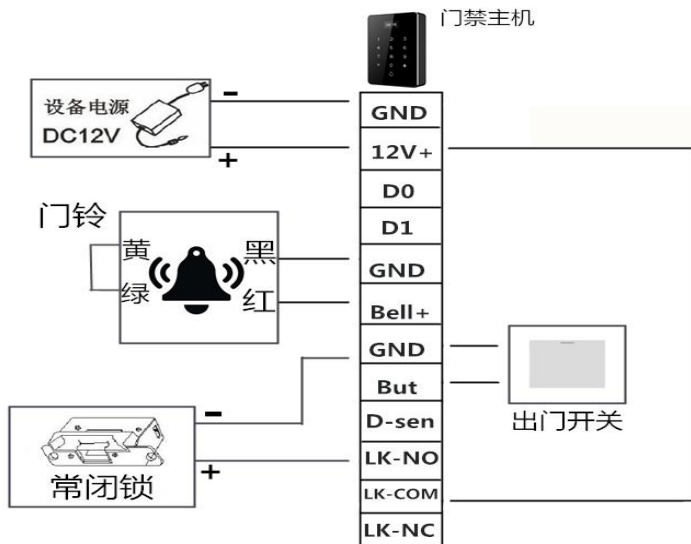

7.2常开锁接线 如图

