



Double door 280KG
Electromagnetic lock

EL-600D, EL-600DS, EL-600DST

Specifications

EL-600D	Without Signal Output	
EL-600DS	With LED (Red only)	
EL-600DST	LED, door sensor and time delay	  
Lock Size	500Lx48.5Wx25H(mm)	
Armature Plate	180Lx38Wx11H(mm)	
Holding Force	280kgx2 (350Lbsx2)	
Voltage	DC12V or DC24V (adjustable)	
Current Draw	12V/500mAx2 24V/250mAx2	
Signal Output	Dry Contact, Max Rating of Contact Current 3A	
Surface Temp	≤20°C	
Operating Temp	-10°C ~ 55°C (14°F~131°F)	
Suitable Humidity	0~90%(non-condensing)	
Finishes for Shell	Anodized aluminum surface texture processing	
Finishes for Magnetic	Zinc	
Finishes for Armature	Zinc	
Weight	4kg	
Standard Packing	4pcs	

Dimensions

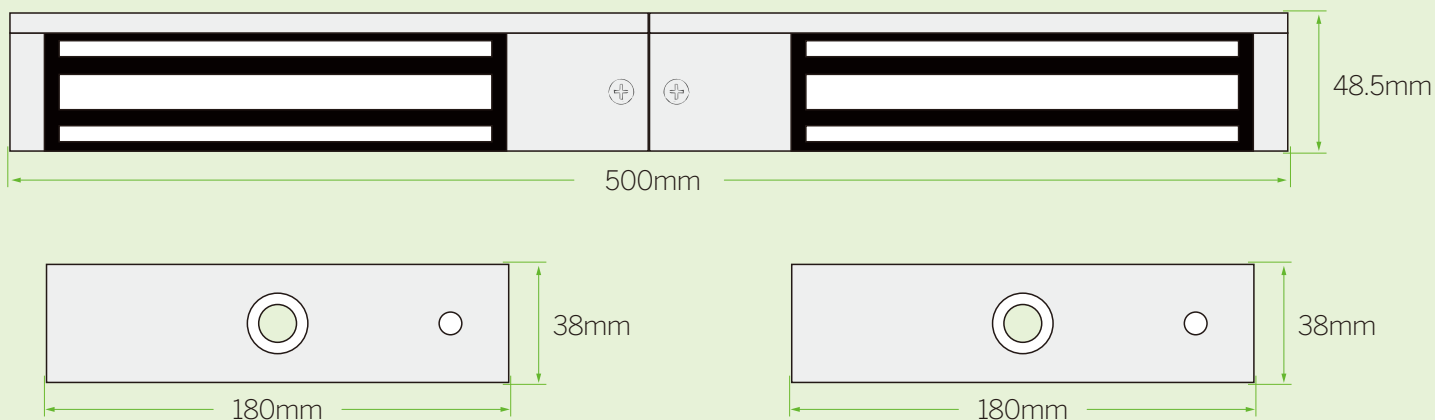

Wiring diagram

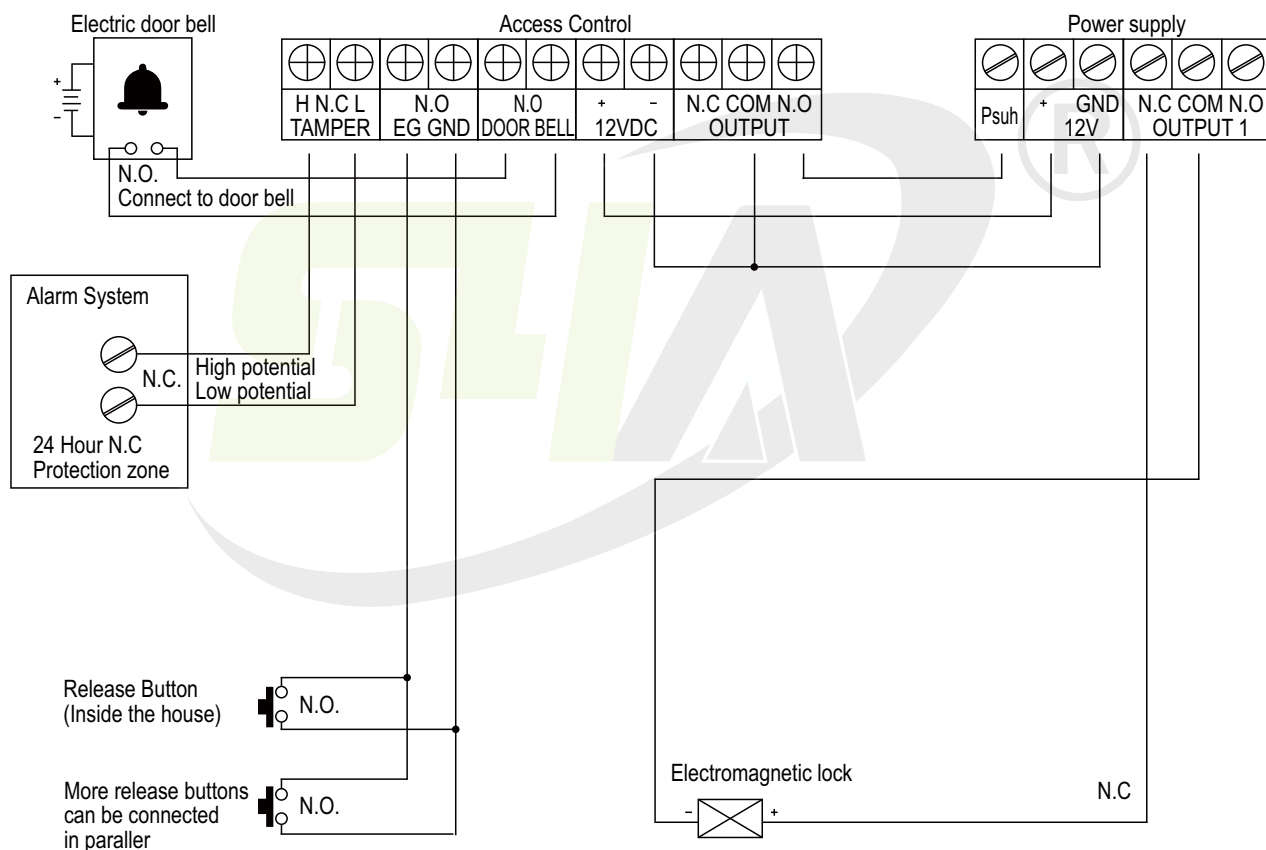

S4A Industrial Co., Limited

Address: 2nd floor of Jinmin Industrial Zone,
Bulong Rd, Bantian St. Longgan Dist, Shenzhen, China

www.S4A.com.cn

E-mail: sales@S4A.cn / Skype: crypton0929
Mob/Whatsapp/Wechat/Viber: +86 130 4080 0588