





## Single door 500KG Electromagnetic lock

EL-1200D, EL-1200SD, EL-1200SZ, EL-1200ST

### Specifications

EL-1200	Without indicator lights	
EL-1200SD	LED, door sensor	 
EL-1200ST	LED, door sensor, Time delay	  
EL-1200SZ	LED, door sensor, Buzzer	  
Lock size	265Lx72Wx40H(mm)	
Armature Plate	185Lx60Wx13H(mm)	
Holding Force	500kg (1200Lbs)	
Voltage	DC12V or DC24V (adjustable)	
Current Draw	12V/420mA 24V/210mA	
Signal Output	Dry Contact, Max Rating of Contact Current 3A	
Surface Temp	≤20°C	
Operating Temp	-10°C ~ 55°C (14°F~131°F)	
Suitable Humidity	0~90%(non-condensing)	
Finishes for Shell	Anodized aluminum surface texture processing	
Finishes for Magnetic	Zinc	
Finishes for Armature	Zinc	
Weight	4.5kg	
Standard Packing	4pcs	

## Dimensions

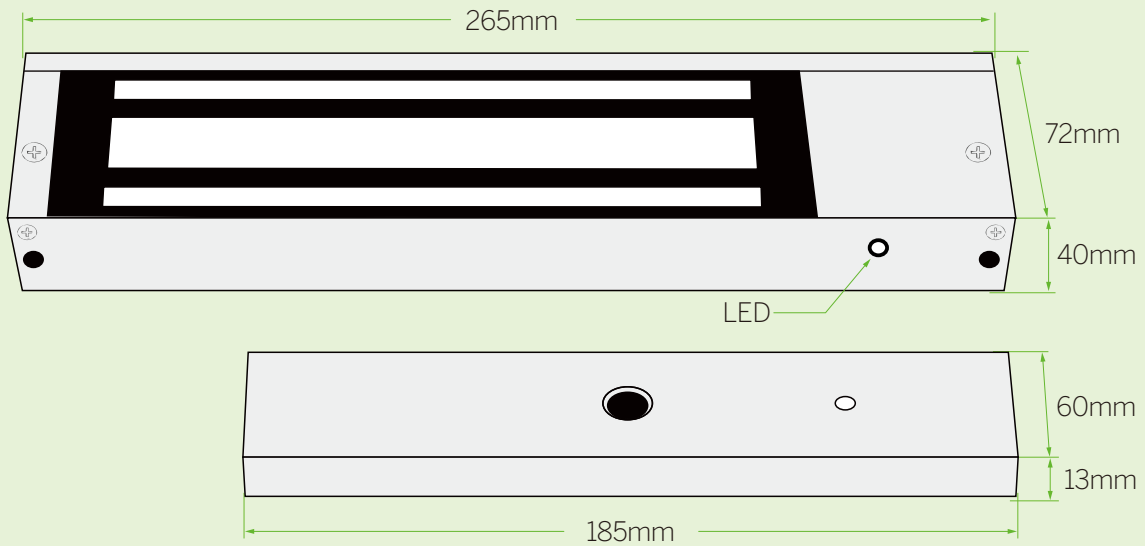

## Wiring diagram

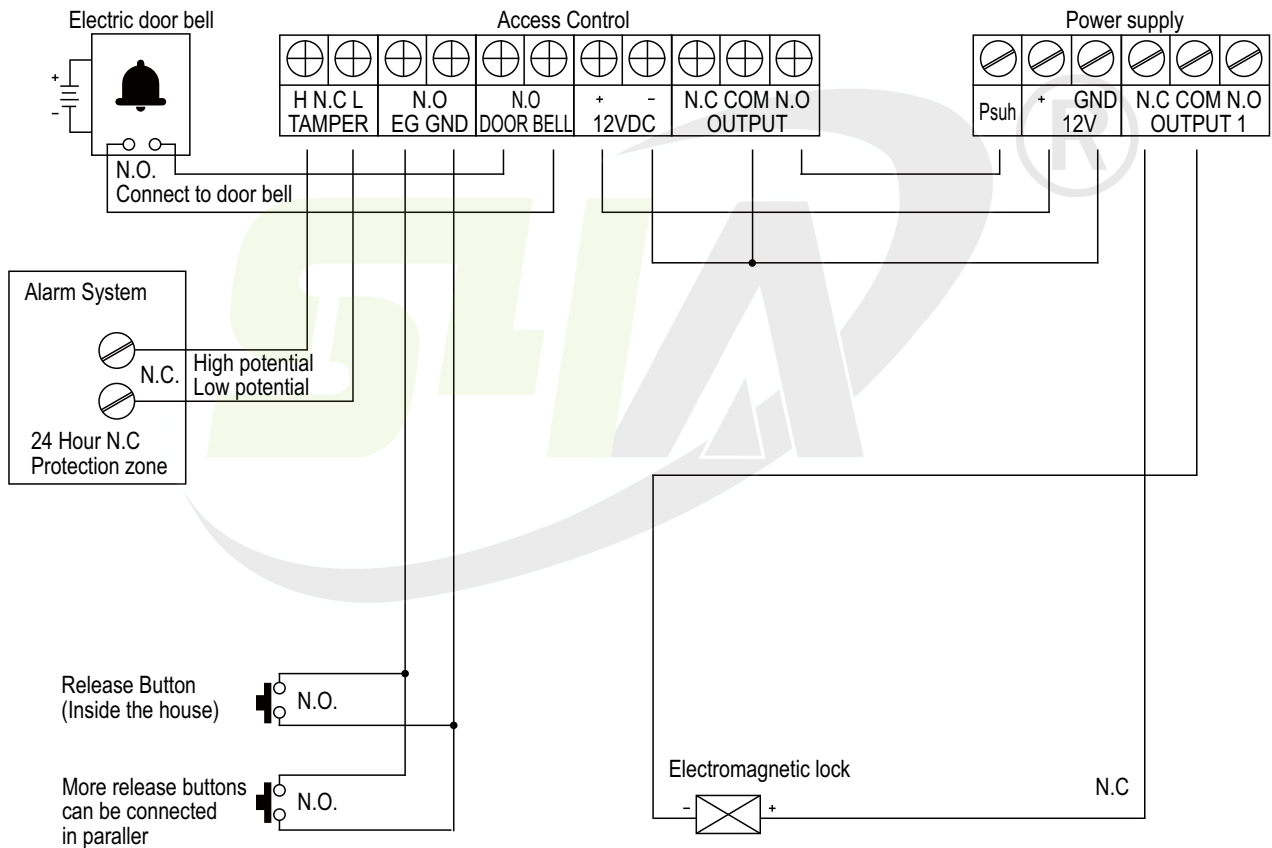

S4A Industrial Co., Limited

Address: 2nd floor of Jinminan Industrial Zone,  
Bulong Rd, Bantian St. Longgan Dist, Shenzhen, China

[www.S4A.com.cn](http://www.S4A.com.cn)

E-mail: [sales@S4A.cn](mailto:sales@S4A.cn) / Skype: crypton0929  
Mob/Whatsapp/Wechat/Viber: +86 130 4080 0588