



Access Control Panel



ACB-T01



ACB-T02



ACB-T04

What is Access Control?

Access control is focussed on controlling who has access, e.g. to an office or facility. This is typically achieved by restricting access by certain types of groups or access levels. With access control visitors, employees, executives, freelancers or employees can easily and securely access.

There are different fields of access control such as network access control, web-server access control and standalone access control. Unlike open access, access control provides control and security to address security and convenience to keep your business running securely.

Specifications

Parameter	Single Door Control Panel	Multi Door (2) Control Panel	Multi Door (4) Control Panel
Model #	ACB-T01	ACB-T02	ACB-T04
Communication	TCP/IP 10M/100M adaptive	TCP/IP 10M/100M adaptive	TCP/IP 10M/100M adaptive
Description	Control 1 door, get in and out door by swiping card, or get in by swiping card and get out door by button	Control 2 doors, get in and out door by swiping card, or get in by swiping card and get out door by button	Control 4 doors, get in the door by swiping card, and get out door by button
Size of PCB board	160mm*106mm	160mm*106mm	218mm*106mm
Size of Case	273mm*228mm*65mm		
Power Supply	12VDC 4-7A		
Power Consumption of Circuit Board	Less than 100mA		
Input Format of Reader	Wiegand 26 (All card reader with compatible protocol, such as Motorola ,HID,EM,Mifare one etc)		
Quantity of Readers	2 pcs	4 pcs	4 pcs
Door Controlled	1 door	2 doors	4 doors
Door opening time extending setting	1-600 seconds(adjustable)		
Max q' ty of controller	No limit		

Operation Temperature	-40 °C ~ 70 °C		
Operation Humidity	10-90 % RH , No Condensation		
Q' ty of users	20,000 Users		
Q' ty of Event Buffers (offline)	100,000 event buffers		
Power interruption protection measure	High Speed Memory, Records never lose		
Max Distance from Reader to Controller	100m (suggestion distance 80m)		
Max Distance between Controllers	TCP/IP: Depends on net coverage area		
Package included	PCB board, software, manual, certificate. carton		
Alarm for long time door open, illegal break in, intimidate	Yes		
Fire and alarm linkage	If no connection with the expansion board, only has software interface alarm, and drive the computer speaker. If connected with expansion board, is able to alarm by hardware, if connected with strengthened expansion board, then is able to Security alarm, Model is ACB-EA05		
Complisive open and close door at long time	Yes		
Open door in remote distance	Yes		
Inter block	No	Yes	Yes
Anti pass back and tail	Yes	Yes	Yes
Multi-card open door	Yes		
Open long time at specified time	Yes		
Electronic map	Yes		
Urgency locking	Yes		
First card unlocking	Yes		
Unlock based on internal and external validation	Yes		
Keypad (card+passwor, supper password)	Yes		

Powerful function for ACB board software



Wiring diagram for ACB-T01 Single door Access Control Board

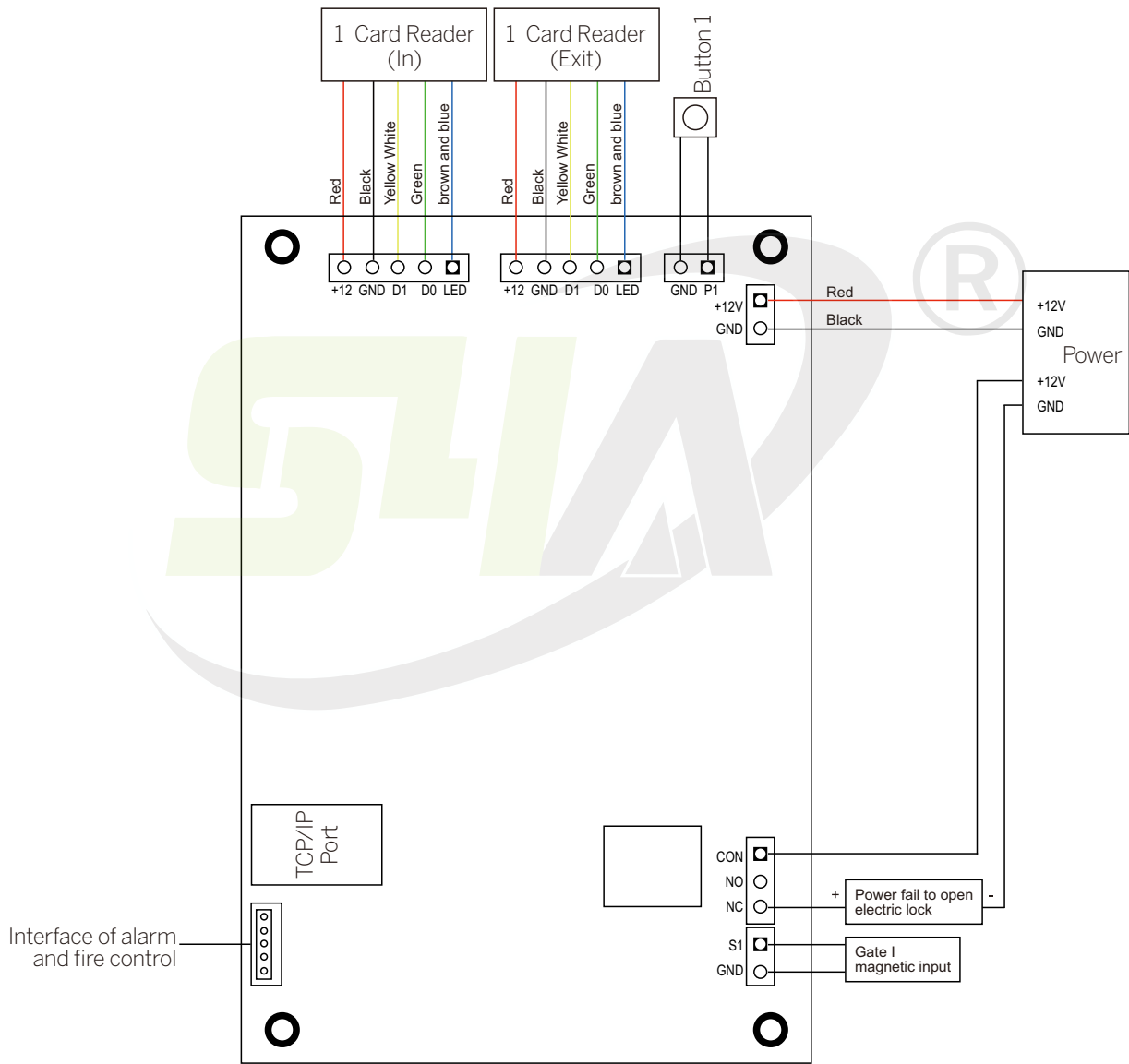

Wiring standard

(Even the connection distance is very short, it must be implemented according to the following requirement)

+220V AC Power cable:

The-wire power supply, the cross-sectional area 1.0mm or more. It's required that power supply must be grounded to prevent from power interference

+The line of electric lock to controller:

It's recommended to use two-wire power line, the cross-sectional area 1.0mm² or more. If the distance over 50 meters, it's considered to use thicker line or multiple parallel

+TCP/IP Communication Line:

Network cable

+The card reader, door sensor and button line:

Can use network cable or others

Wiring diagram for ACB-T02 Multi door Access Control Board

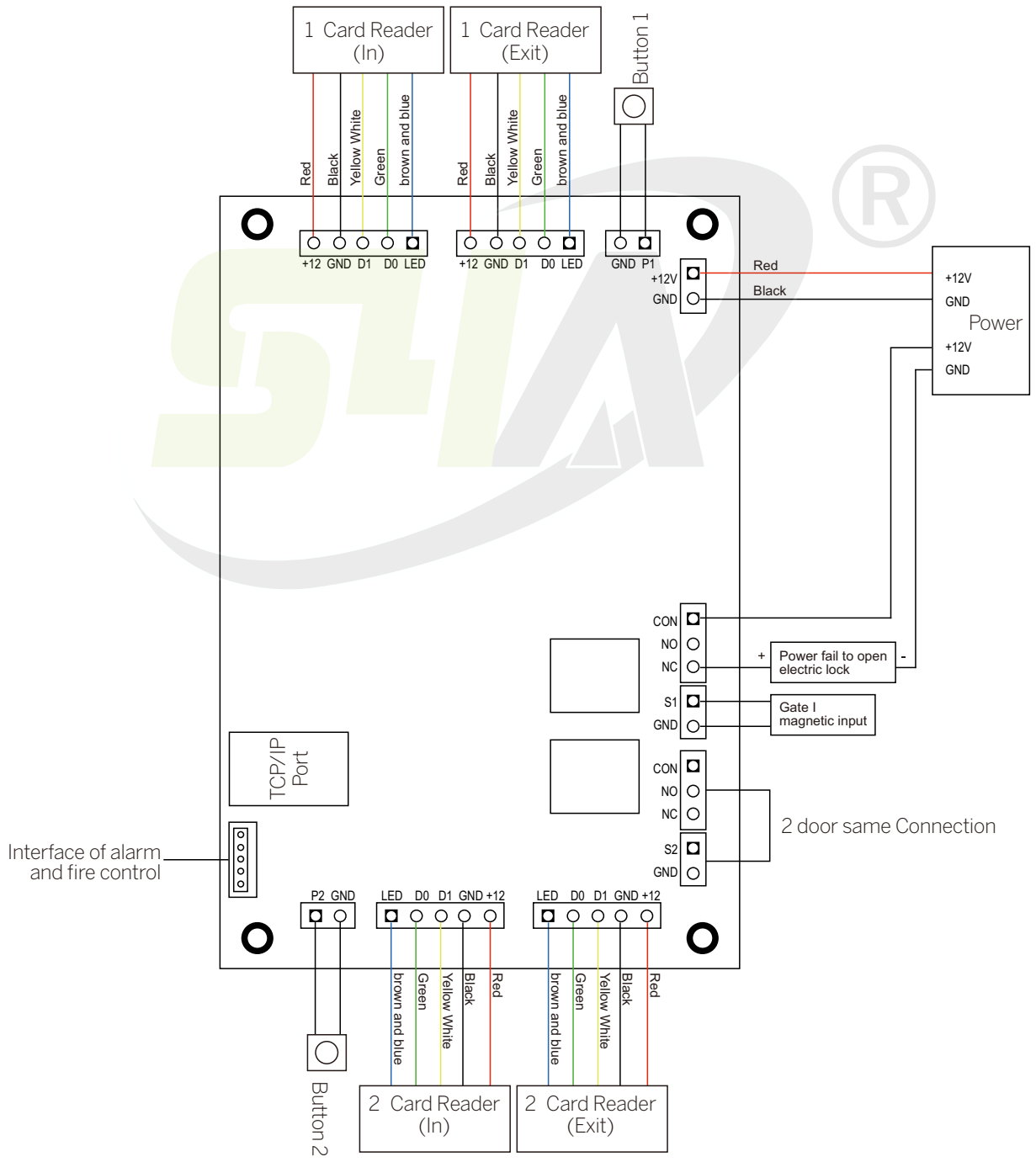

Wiring diagram for ACB-T04 Multi door Access Control Board

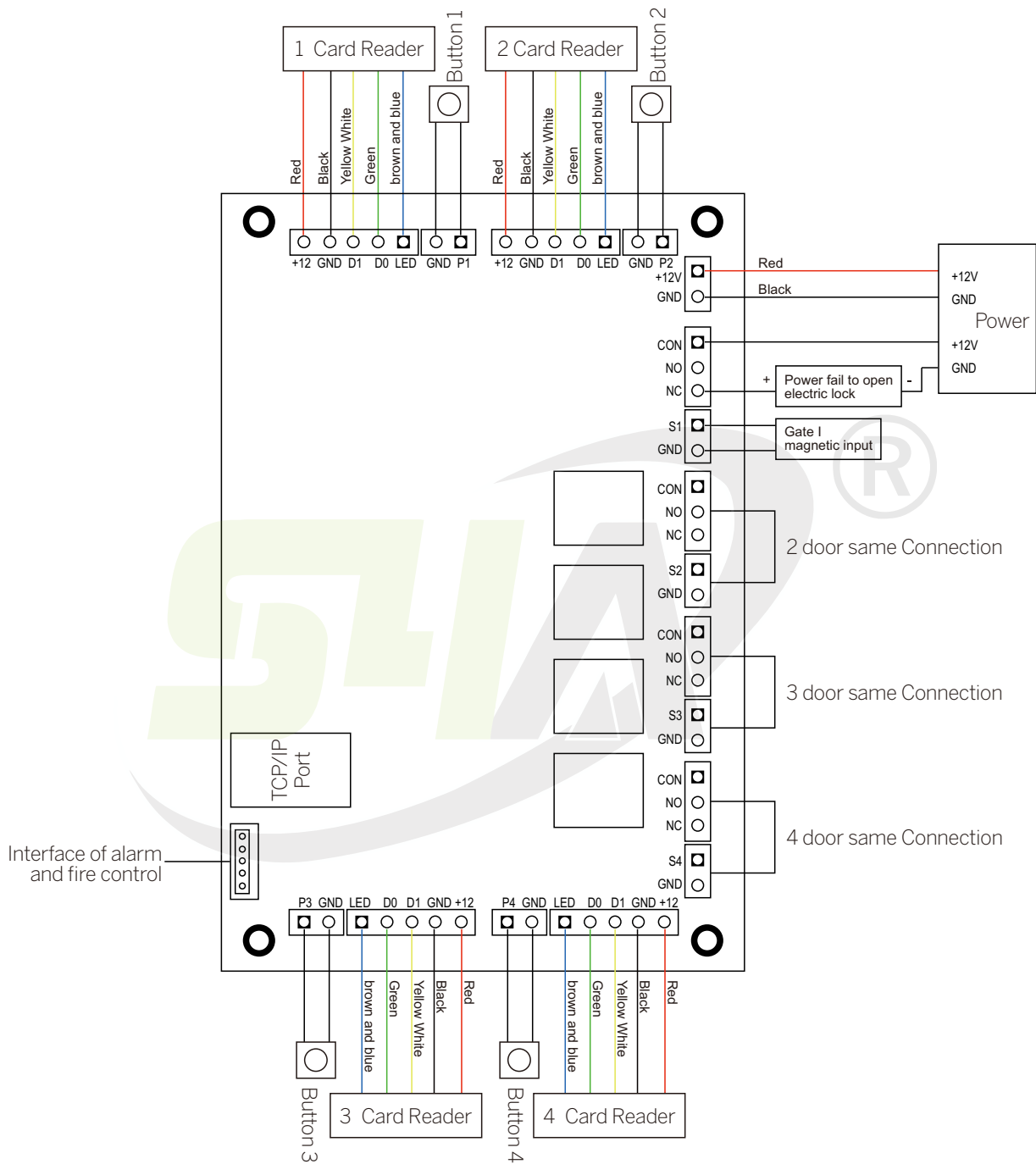

S4A Industrial Co., Limited

Address: 2nd floor of Jinmin Industrial Zone,
Bulong Rd, Bantian St. Longgan Dist, Shenzhen, China

www.S4A.com.cn

E-mail: sales@S4A.cn / Skype: crypton0929
Mob/Whatsapp/Wechat/Viber: +86 130 4080 0588